

PHB-113/213 Standard Jaws HYDRAULIC PULLER

Page 1 of 2

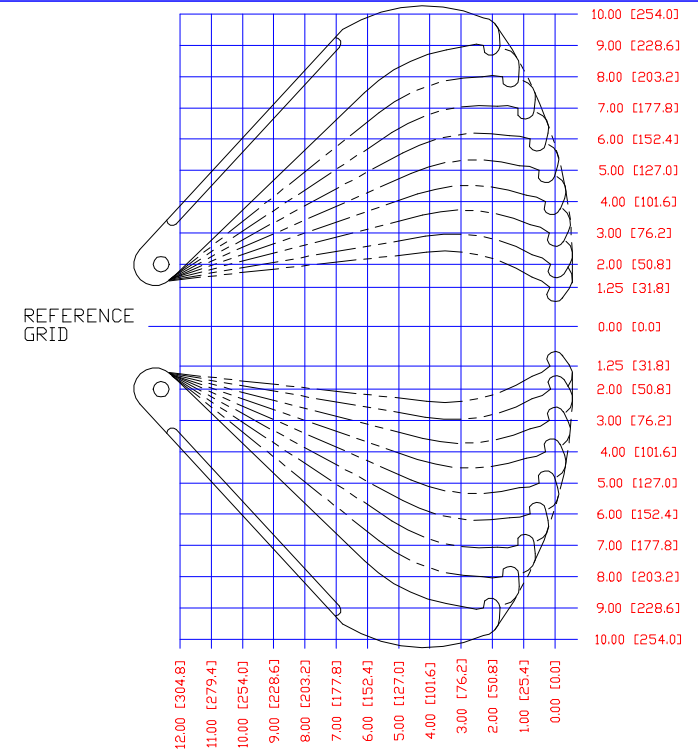
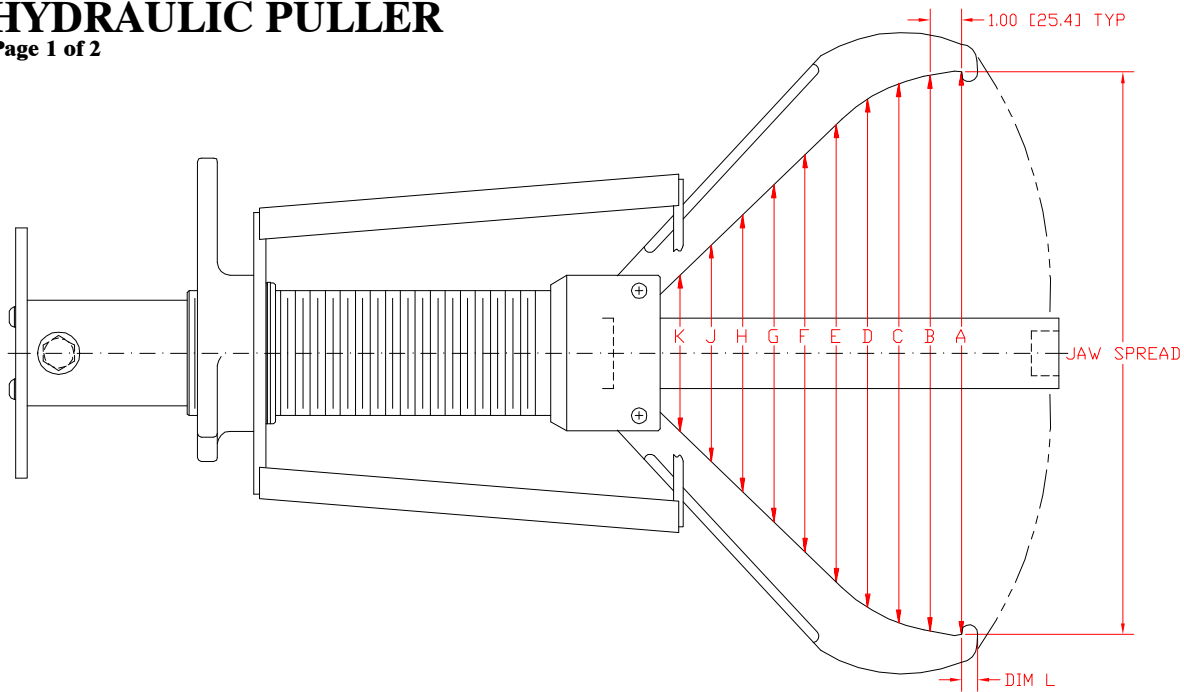

JAW SPREAD	DIM A	DIM B	DIM C	DIM D	DIM E	DIM F	DIM G	DIM H	DIM J	DIM K	DIM L
2.50 [63.5]	4.53 [115.1]	4.82 [122.4]	4.73 [120.1]	4.51 [114.6]	4.29 [109.0]	4.06 [103.1]	3.84 [97.5]	3.62 [91.9]	3.40 [86.4]	3.18 [80.8]	.617 [15.67]
4.00 [101.6]	5.76 [146.3]	5.94 [150.9]	5.74 [145.8]	5.40 [137.2]	5.05 [128.3]	4.71 [119.6]	4.36 [110.7]	4.02 [102.1]	3.67 [93.2]	3.33 [84.6]	.618 [15.70]
6.00 [152.4]	7.38 [187.5]	7.45 [189.2]	7.12 [180.8]	6.61 [167.9]	6.09 [154.7]	5.58 [141.7]	5.07 [128.8]	4.55 [115.6]	4.04 [102.6]	3.53 [89.7]	.615 [15.62]
8.00 [203.2]	9.02 [229.1]	8.98 [228.1]	8.56 [217.4]	7.87 [199.9]	7.18 [182.4]	6.49 [164.8]	5.80 [147.3]	5.11 [129.8]	4.42 [112.3]	3.73 [94.7]	.609 [15.47]
10.00 [254.0]	10.68 [271.3]	10.57 [268.5]	10.07 [255.8]	9.21 [233.9]	8.33 [211.6]	7.46 [189.5]	6.58 [167.1]	5.70 [144.8]	4.82 [122.4]	3.94 [100.1]	.598 [15.19]
12.00 [304.8]	12.38 [314.5]	12.23 [310.6]	11.67 [296.4]	10.68 [271.2]	9.59 [243.6]	8.51 [216.2]	7.42 [188.5]	6.34 [161.0]	5.25 [133.4]	4.16 [105.7]	.583 [14.81]
14.00 [355.6]	14.14 [359.1]	13.97 [354.8]	13.40 [340.4]	12.33 [313.2]	11.01 [279.7]	9.69 [246.1]	8.37 [212.6]	7.04 [178.8]	5.72 [145.3]	4.40 [111.8]	.564 [14.33]
16.00 [406.4]	15.97 [405.6]	15.82 [401.8]	15.25 [387.4]	14.20 [360.7]	12.65 [321.3]	11.05 [280.7]	9.46 [240.3]	7.86 [199.6]	6.27 [159.3]	4.67 [118.6]	.539 [13.69]
18.00 [457.2]	18.00 [457.2]	17.77 [451.4]	17.26 [438.4]	16.27 [413.3]	14.63 [371.6]	12.70 [322.6]	10.77 [273.6]	8.85 [224.8]	6.92 [175.8]	4.99 [126.7]	.508 [12.90]

POSI LOCK MODELS PHB113\PHB213 GEAR AND BEARING PULLER

MODEL PHB113

25 TON [22.8 METRIC TONS]
3 JAW - STANDARD
RAM STROKE 14.25 [362.0]
REACH 12.0 [304.8]
SPREAD 2.5 [63.5] TO 18.0 [457.2]
WT. 116 Lbs.[52.7 kg]
RATED FOR 10000 PSI

MODEL PHB213

25 TON [22.8 METRIC TONS]
2 JAW - STANDARD
RAM STROKE 14.25 [362.0]
REACH 12.0 [304.8]
SPREAD 2.5 [63.5] TO 18.0 [457.2]
WT. 98 Lbs.[44.5 kg]
RATED FOR 10000 PSI

PHB-113/213 Standard Jaws HYDRAULIC PULLER

Page 2 of 2

RAM POINT SET

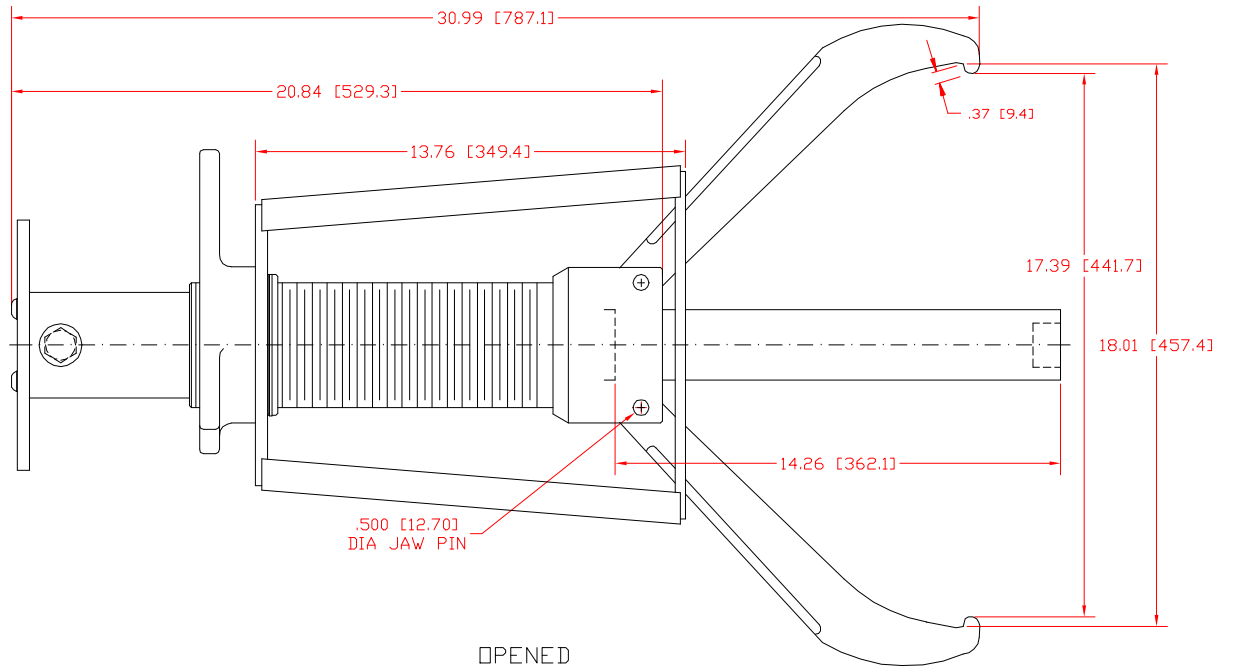
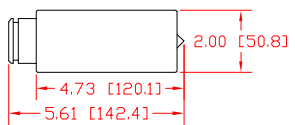
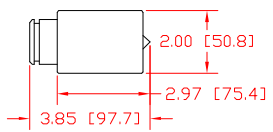
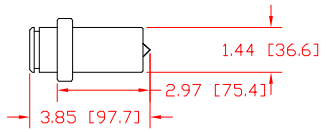
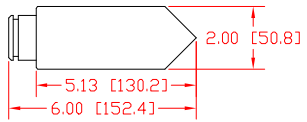
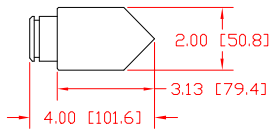
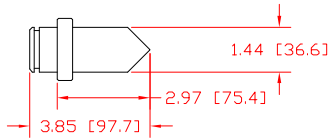

OPENED

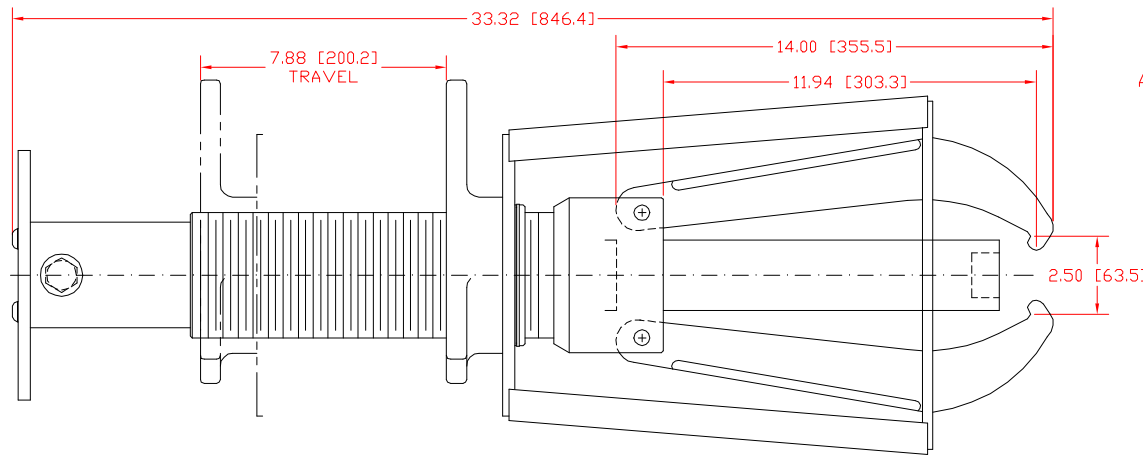

CLOSED

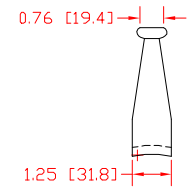

R2.50 [R63.6]

VIEW A-A
JAW ONLY