

108 / 208 (Long Jaw)

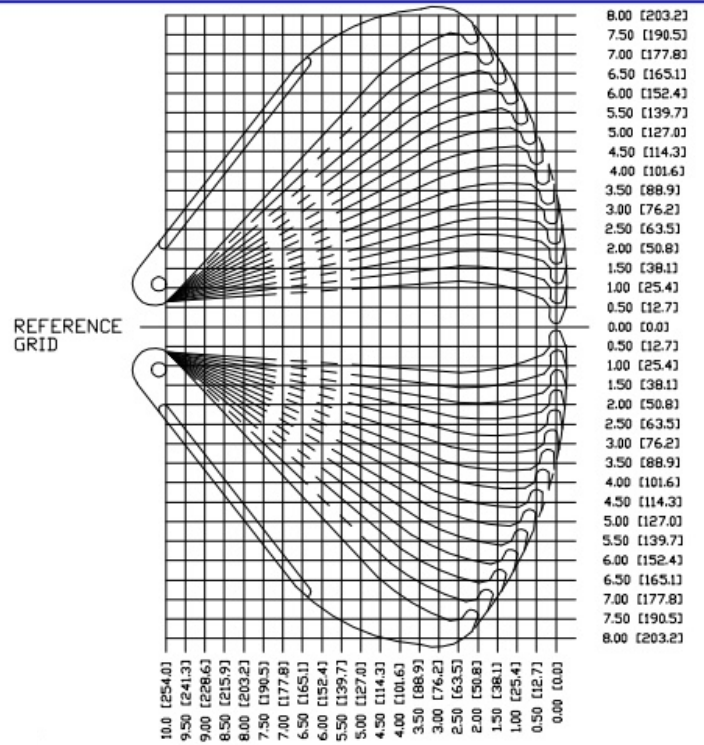
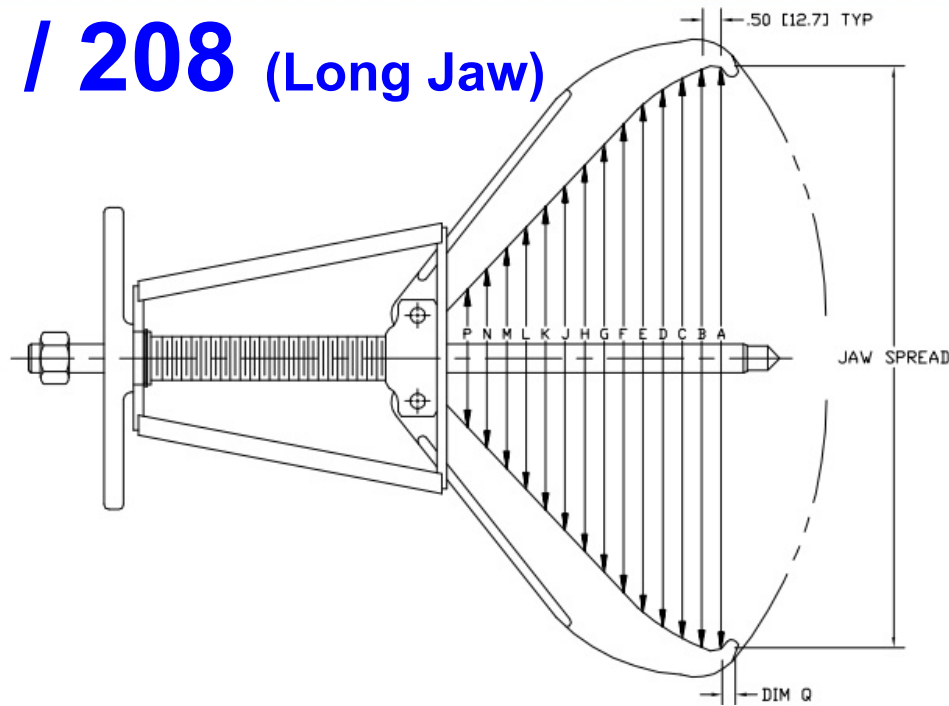

JAW SPREAD	DIM A	DIM B	DIM C	DIM D	DIM E	DIM F	DIM G	DIM H	DIM J	DIM K	DIM L	DIM M	DIM N	DIM P	DIM Q
3.00 [76.2]	3.89 [98.8]	3.73 [94.7]	3.55 [90.2]	3.38 [85.9]	3.21 [81.5]	3.04 [77.2]	2.87 [72.9]	2.70 [68.6]	2.53 [64.3]	2.35 [59.7]	2.18 [55.4]	2.01 [51.1]	1.84 [46.7]	1.67 [42.4]	0.292 [7.42]
4.00 [101.6]	4.67 [118.6]	4.47 [113.5]	4.24 [107.7]	4.02 [102.1]	3.80 [96.5]	3.57 [90.7]	3.35 [85.1]	3.13 [79.5]	2.90 [73.7]	2.68 [68.1]	2.46 [62.5]	2.24 [56.9]	2.01 [51.1]	1.79 [45.5]	0.310 [7.87]
5.00 [127.0]	5.47 [138.9]	5.23 [132.8]	4.95 [125.7]	4.67 [118.6]	4.40 [111.8]	4.12 [104.8]	3.84 [97.5]	3.57 [90.7]	3.29 [83.6]	3.02 [76.7]	2.74 [69.6]	2.46 [62.5]	2.19 [55.6]	1.91 [48.5]	0.326 [8.28]
6.00 [152.4]	6.28 [159.5]	6.01 [152.7]	5.68 [144.3]	5.35 [135.9]	5.02 [127.5]	4.68 [118.9]	4.35 [110.5]	4.02 [102.1]	3.69 [93.7]	3.36 [85.3]	3.03 [77.0]	2.69 [68.3]	2.36 [59.9]	2.03 [51.6]	0.342 [8.69]
7.00 [177.8]	7.12 [180.8]	6.83 [173.5]	6.44 [163.6]	6.05 [153.7]	5.66 [143.8]	5.27 [133.9]	4.88 [124.0]	4.49 [114.0]	4.10 [104.1]	3.71 [94.2]	3.32 [84.3]	2.94 [74.7]	2.55 [64.8]	2.16 [54.9]	0.357 [9.07]
8.00 [203.2]	7.98 [202.7]	7.68 [195.1]	7.23 [183.6]	6.78 [172.2]	6.33 [160.8]	5.88 [149.4]	5.43 [137.9]	4.98 [126.5]	4.53 [115.1]	4.09 [103.9]	3.64 [92.5]	3.19 [81.0]	2.74 [69.6]	2.29 [58.2]	0.371 [9.42]
9.00 [228.6]	8.88 [225.6]	8.55 [217.2]	8.08 [205.2]	7.56 [192.0]	7.05 [179.1]	6.54 [166.1]	6.02 [152.9]	5.51 [140.0]	4.99 [126.7]	4.48 [113.8]	3.96 [100.6]	3.45 [87.6]	2.93 [74.4]	2.42 [61.5]	0.385 [9.78]
10.00 [254.0]	9.81 [249.2]	9.47 [240.5]	8.99 [228.3]	8.40 [213.4]	7.82 [198.6]	7.23 [183.6]	6.65 [168.9]	6.07 [154.2]	5.48 [139.2]	4.90 [124.5]	4.31 [109.5]	3.73 [85.6]	3.15 [80.0]	2.56 [65.0]	0.398 [10.11]
11.00 [279.4]	10.79 [274.1]	10.43 [264.9]	9.96 [253.0]	9.31 [236.5]	8.65 [219.7]	7.99 [202.9]	7.33 [186.2]	6.67 [169.4]	6.01 [152.7]	5.35 [135.9]	4.69 [119.1]	4.03 [102.4]	3.37 [85.6]	2.71 [68.8]	0.410 [10.41]
12.00 [304.8]	11.82 [300.2]	11.45 [290.8]	10.97 [278.6]	10.31 [261.9]	9.57 [243.1]	8.82 [224.0]	8.08 [205.2]	7.34 [186.4]	6.59 [167.4]	5.85 [148.6]	5.11 [129.8]	4.36 [110.7]	3.62 [91.9]	2.88 [73.2]	0.420 [10.67]
13.00 [330.2]	12.90 [327.7]	12.53 [318.3]	12.05 [306.1]	11.43 [290.3]	10.60 [269.2]	9.76 [247.9]	8.92 [226.6]	8.08 [206.2]	7.24 [183.9]	6.41 [162.8]	5.57 [141.5]	4.73 [120.1]	3.89 [98.8]	3.06 [77.7]	0.430 [10.92]
14.00 [355.6]	14.04 [356.6]	13.68 [347.5]	13.20 [335.3]	12.59 [319.8]	11.77 [299.0]	10.82 [274.8]	9.88 [251.0]	8.93 [228.8]	7.99 [202.9]	7.04 [178.8]	6.09 [154.7]	5.15 [130.8]	4.20 [106.7]	3.26 [82.8]	0.439 [11.15]
15.00 [381.0]	15.00 [381.0]	14.90 [378.5]	14.44 [366.8]	13.84 [351.5]	13.09 [332.5]	12.07 [306.6]	10.99 [279.1]	9.92 [252.0]	8.85 [224.8]	7.78 [197.6]	6.71 [170.4]	5.63 [143.0]	4.56 [115.8]	3.49 [88.6]	0.446 [11.33]

<p>MODEL 108L 17 TON [151 kN] 3 JAW REACH 9.67 [245.6] SPREAD 3.0 [76.2] TO 15.0 [381.0] WT. 14.25 Lbs. [6.6 kg] MAXIMUM TORQUE 220 FOOT POUNDS [299 N.m]</p>	<p>MODEL 208L 12 TON [107kN] 2 JAW REACH 9.67 [245.6] SPREAD 3.0 [76.2] TO 15.0 [381.0] WT. 12 Lbs. [5.4 kg] MAXIMUM TORQUE 150 FOOT POUNDS [204 N.m]</p>
--	--

108 / 208 (Long Jaw)

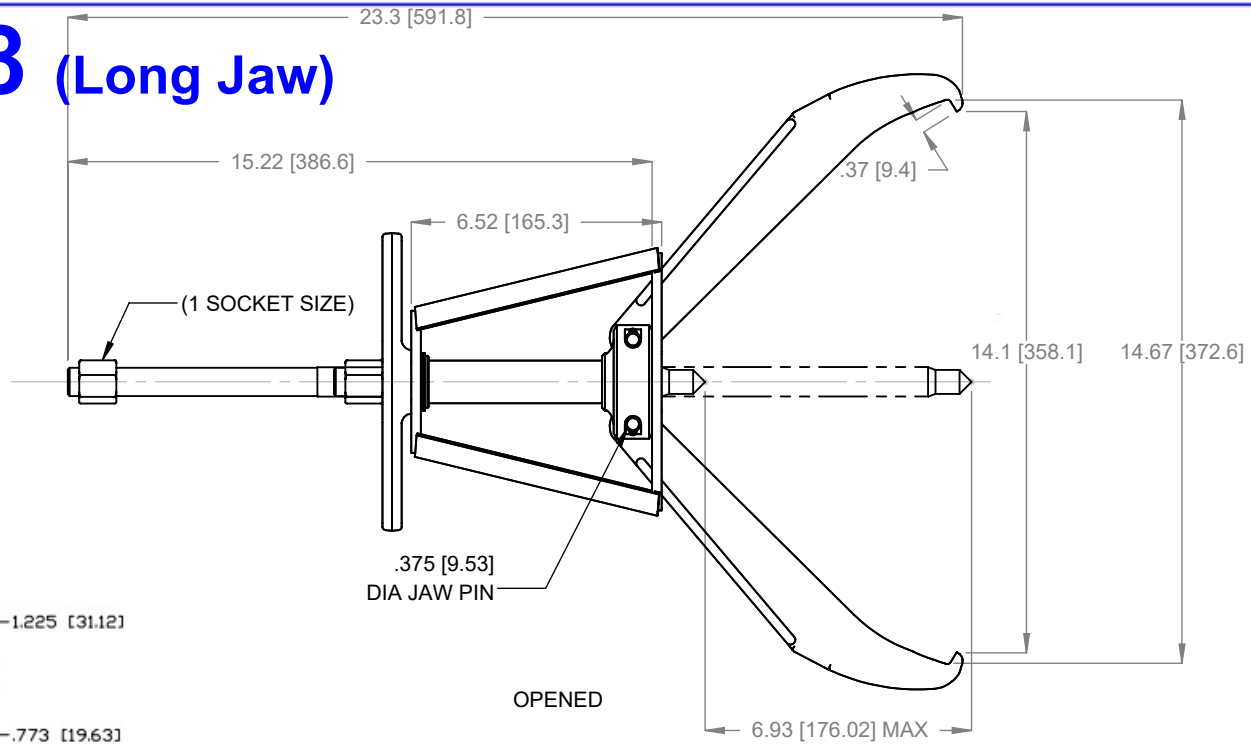

OPTIONAL SHAFT EXTENSION
INCREASES CENTER BOLT
LENGTH BY 1.5"

