

# 108 / 208 (Extra Long Jaw)

MODEL 108L  
 17 TON [151 kN]  
 3 JAW  
 REACH 15.78 [400.8]  
 SPREAD 4.0 [101.6] TO 22.0 [558.8]  
 WT. 21.0 Lbs. [9.5 kg]  
 MAXIMUM TORQUE  
 220 FOOT POUNDS [299 N.m]

MODEL 208L  
 12 TON [107kN]  
 2 JAW  
 REACH 15.78 [400.8]  
 SPREAD 4.0 [101.6] TO 22.0 [558.8]  
 WT. 16 Lbs. [7.3 kg]  
 MAXIMUM TORQUE  
 150 FOOT POUNDS [204 N.m]

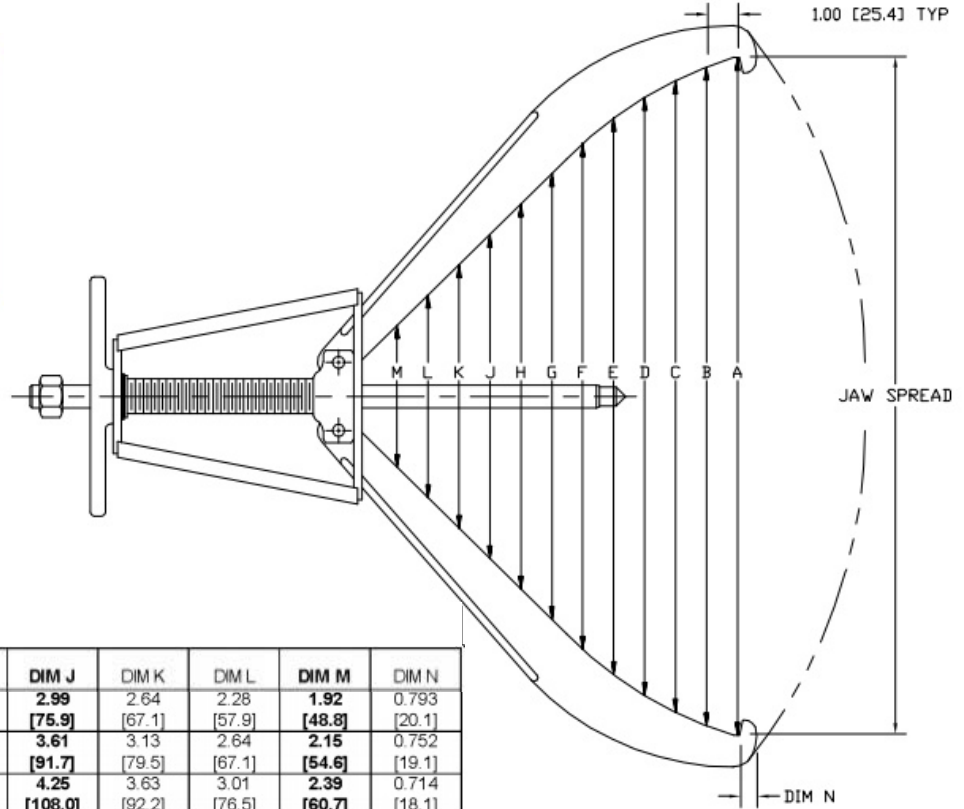

JAW SPREAD	DIM A	DIM B	DIM C	DIM D	DIM E	DIM F	DIM G	DIM H	DIM J	DIM K	DIM L	DIM M	DIM N
4.00 [101.6]	5.20 [132.1]	5.22 [132.6]	<b>5.08 [129.0]</b>	4.79 [121.7]	4.43 [112.5]	<b>4.07 [103.4]</b>	3.71 [94.2]	3.35 [85.1]	<b>2.99 [75.9]</b>	2.64 [67.1]	2.28 [57.9]	<b>1.92 [48.8]</b>	0.793 [20.1]
6.00 [152.4]	6.79 [172.5]	6.70 [170.2]	<b>6.46 [164.1]</b>	6.05 [153.7]	5.56 [141.2]	<b>5.07 [128.8]</b>	4.59 [116.6]	4.10 [104.1]	<b>3.61 [91.7]</b>	3.13 [79.5]	2.64 [67.1]	<b>2.15 [54.6]</b>	0.752 [19.1]
8.00 [203.2]	8.40 [213.4]	8.22 [208.8]	<b>7.87 [199.9]</b>	7.36 [186.9]	6.74 [171.2]	<b>6.11 [155.2]</b>	5.49 [139.4]	4.87 [123.7]	<b>4.25 [108.0]</b>	3.63 [92.2]	3.01 [76.5]	<b>2.39 [60.7]</b>	0.714 [18.1]
10.00 [254.0]	10.03 [254.8]	9.78 [248.4]	<b>9.34 [237.2]</b>	8.72 [221.5]	7.97 [202.4]	<b>7.20 [182.9]</b>	6.44 [163.6]	5.68 [144.3]	<b>4.92 [125.0]</b>	4.16 [105.7]	3.40 [86.4]	<b>2.63 [66.8]</b>	0.677 [17.2]
12.00 [304.8]	11.78 [299.2]	11.41 [289.8]	<b>10.87 [276.1]</b>	10.16 [258.1]	9.28 [235.7]	<b>8.36 [212.3]</b>	7.45 [189.2]	6.54 [166.1]	<b>5.63 [143.0]</b>	4.72 [119.9]	3.80 [96.5]	<b>2.89 [73.4]</b>	0.641 [16.3]
14.00 [355.6]	13.57 [344.7]	13.12 [333.2]	<b>12.50 [317.5]</b>	11.85 [301.0]	10.69 [271.5]	<b>9.61 [244.1]</b>	8.54 [216.9]	7.46 [189.5]	<b>6.39 [162.3]</b>	5.31 [134.9]	4.24 [107.7]	<b>3.16 [80.3]</b>	0.608 [15.4]
16.00 [406.4]	15.46 [392.7]	14.94 [379.5]	<b>14.24 [361.7]</b>	13.35 [339.1]	12.24 [310.9]	<b>10.99 [279.1]</b>	9.73 [247.1]	8.48 [215.4]	<b>7.22 [183.4]</b>	5.97 [151.6]	4.72 [119.9]	<b>3.46 [87.9]</b>	0.576 [14.6]
18.00 [457.2]	17.48 [444.0]	16.89 [429.0]	<b>16.12 [409.4]</b>	12.15 [308.6]	13.95 [354.3]	<b>12.53 [318.3]</b>	11.07 [281.2]	9.61 [244.1]	<b>8.16 [207.3]</b>	6.70 [170.2]	5.24 [133.1]	<b>3.79 [96.3]</b>	0.547 [13.9]
20.00 [508.0]	19.65 [499.1]	19.00 [482.6]	<b>18.17 [461.5]</b>	17.13 [435.1]	15.86 [402.8]	<b>14.29 [363.0]</b>	12.60 [320.0]	10.92 [277.4]	<b>9.23 [234.4]</b>	7.54 [191.5]	5.85 [148.6]	<b>4.16 [105.7]</b>	0.520 [13.2]
22.00 [558.8]	22.00 [558.8]	21.31 [541.3]	<b>20.43 [518.9]</b>	19.67 [499.6]	18.00 [457.2]	<b>16.36 [415.5]</b>	14.42 [366.3]	12.46 [316.5]	<b>10.49 [266.4]</b>	8.53 [216.7]	6.56 [166.6]	<b>4.60 [116.8]</b>	0.492 [12.5]

# 108 / 208 (Extra Long Jaw)

## SHAFT PROTECTOR

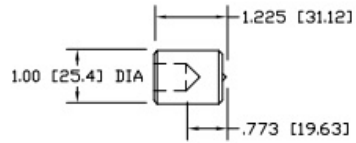

OPTIONAL SHAFT EXTENSION  
INCREASES CENTER BOLT  
LENGTH BY 1.5"

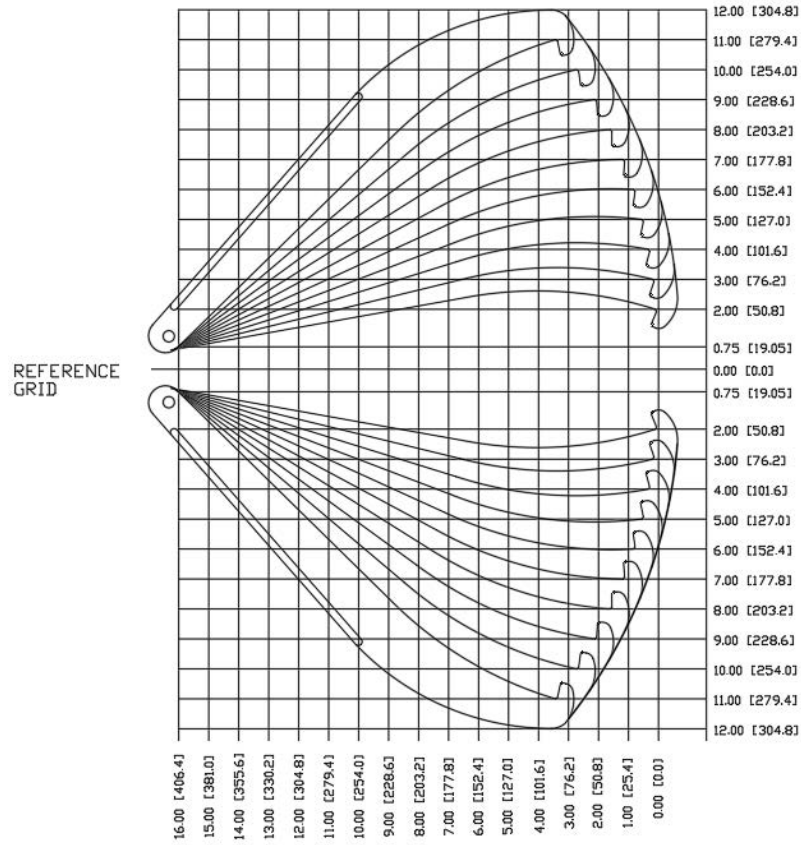
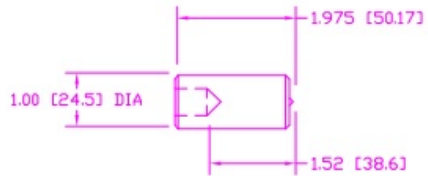

# 108 / 208 (Extra Long Jaw)

