

Posi Lock Puller Identification Sheet

Below are specific dimensions that are necessary to determine Posi Lock puller sizes:

- A** Center Bolt Diameter
- B** Reach
- C** Spread Range
- D** Overall Length
- E** Jaw Width
- F** Hex Socket Size

If your Posi Lock label is missing, you can use the additional information to determine your puller model number.

** All measurements are in INCHES!*

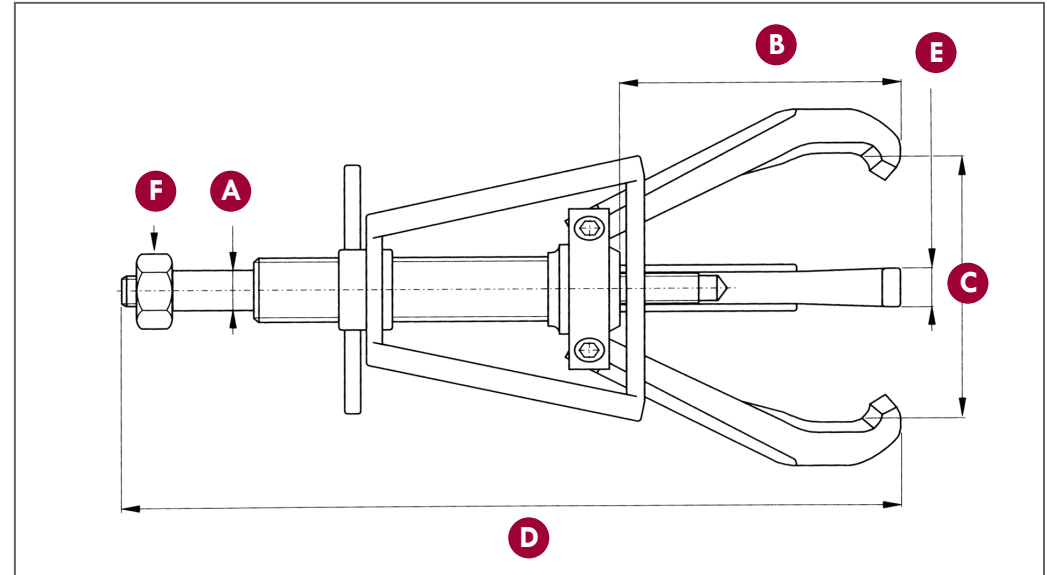

| Model # | Length | Center Bolt Diameter | Nut | Jaw Length | Jaw Width | Cage Height | Cage Top | Cage Bottom | Jaw Head Length | Jaw Head Width | T-Handle Length | T-Handle Width |
|---------|--------|----------------------|-------|------------|-----------|-------------|----------|-------------|-----------------|----------------|-----------------|----------------|
| 102/202 | 5 1/2 | 5/16 | - | 2 5/8 | - | - | - | - | - | - | - | - |
| 103/203 | 7 | 3/8 | - | 3 5/8 | - | 2 3/4 | - | - | - | - | - | - |
| 104/204 | 10 1/8 | 1/2 | 3/4 | 5 | 5/8 | 4 1/4 | 3 | 4 | 4 1/2 | 2 1/4 | 5 | 1 1/2 |
| 106/206 | 13 | 5/8 | 3/4 | 7 1/4 | 1 | 5 | 3 1/4 | 5 3/4 | 5 1/2 | 2 1/2 | 6 1/2 | 1 3/4 |
| 108/208 | 16 1/2 | 3/4 | 1 | 9 1/2 | 7/8 | 6 1/2 | 3 7/8 | 6 7/8 | 6 1/2 | 3 | 7 3/4 | 1 3/4 |
| 110/210 | 19 1/2 | 3/4 | 1 | 11 | 1 3/4 | 8 | 4 | 7 | 8 1/4 | 3 | 8 | 1 3/4 |
| 113/213 | 26 1/4 | 1 1/8 | 1 1/4 | 14 | 2 | 10 1/2 | 6 1/2 | 11 1/2 | 11 1/2 | 5 | 10 | 2 3/4 |
| 116/216 | 31 3/4 | 1 1/4 | 1 1/4 | 16 3/4 | 2 1/2 | 13 1/2 | 7 3/4 | 12 3/4 | 12 3/4 | 6 | 12 | 3 1/4 |

For more information on how to determine puller size or questions on dimensions contact a Posi Lock Sales Executive at: 1-701-797-2600.

| Model # | Long Jaw Length |
|---|-----------------|
| 110/210 | 18 |
| 113/213 | 21 |
| 116/216 | 28 |
| <i>*Measurement have been rounded UP!</i> | |

| Model # | Inside Diameter |
|---------|-----------------|
| HP-30 | 1 1/4 - 1/12 |
| HP-40 | 1 3/4 - 2 |
| HP-50 | 2 1/2 - 3 |

| Model # | Thread Count |
|---------|----------------------------|
| 104/204 | 16 rolled threads per INCH |
| 103/203 | 24 threads per INCH |